

Art. 7. 2023 FIA CENTRAL EUROPEAN ZONE RALLYCROSS CHAMPIONSHIP

7.1 Eligible Cars

For all Divisions and classes (if not otherwise defined in the resp. Div./class) is valid:

- Drivers-equipment according valid FIA-Homologations (except SuperTouringCars).
- Cut slick-tyres according definition of FIA App. "J" 2015, Art. 9.2 are allowed.
- The use of a FHR (HANS®) System is mandatory to all participants for SuperCars and Super1600 - for SuperTouringCars (STC) it is strongly recommended.
- Fire extinguisher systems are recommended.
- Diesel-engine is not allowed.

SuperCars: 4WD-cars up to 3.500 cc or 2WD-cars (no limits of cubic capacity), conforming to the FIA RX regulations 2020 (SuperCars conforming to the FIA RX regulations 2012 until 2019 are allowed); R5, Super-Lite

Min. weights (incl. driver and equipment) according FIA App. "J", Art.279.

+1600-2000 cc = 1.100 kg;

+2000-2500 cc = 1.130 kg;

+2500-3000 cc = 1.210 kg;

+3000-3500 cc = 1.300 kg;

+3500 cc = 1.380 kg.

Additionally, cars with expired homologation from actually SuperTouringCars, 4WD, up to 4000 cc, are eligible or 2WD cars (no limits of cubic capacity), are eligible.

To make sure, that cars from SuperTouringCars can compete with the modern ones, the following exceptions are defined:

- Air-restrictor and safety-equipment according valid FIA rules; dashboard free; cars must be equipped with catalytic converter; noise-limit 100 dB.
- Min. weights (incl. driver and equipment): see above.

Super1600: According valid FIA-rules 2014 to 2021 (The cars must be homologated in the Year 2010 or later acc. FIA).

SuperTouringCars (Group H): All cars must correspond with 2024 SEZ Technical regulations for STC. See Appendix 1 RX

Drivers must to be equipped by safety overall with FIA Hologram label.

7.2 Competition Numbers

On the lower part of the left and right rear side windows of the car, the national flag of the driver and the driver's surname will displayed between 6 cm and 10 cm high. The two numbers for each rear side window shall be 20 cm high with a stroke width of 40 mm, coloured fluorescent orange (PMS 804). At the top Right side (looking from inside the car) of the front window there shall be a fluorescent orange (PMS 804) competition number (14 cm high) on a clear background. One matt white roof panel (35 cm wide by 35 cm high), must be placed on the roof with the top towards the front of the car. A matt black competition number, 5 cm wide by 28 cm high, will be displayed on this panel,

Competition numbers will be allocated as follows:

| | | | |
|------------------------|------------|------------------------|------------|
| Supercars: | 1 to 99 | Super1600: | 101 to 199 |
| SuperTouringcars-2000: | 201 to 299 | SuperTouringCars-1600: | 301 to 399 |
| SuperTouringCars+2000: | 401 to 499 | | |

7.3 Competitions counting towards the Championship

Venues and dates according the FIA CEZ Championship Calendar; see www.cez-motorsport.com).

Should the number of qualifying competitions organised finally be less than three, the Championship would be considered as not having taken place.

At least one of the Stewards must be nominated from one of the other CEZ ASNs. All decisions have to be issue in English by FIA format.

The foreign Steward must send the results and all the important documents to the secretariat of the CEZ till 48 hours by e-mail.

7.4 Organisation of the competitions

The competitions are to be organised according to the FIA-Sporting Code and its Appendices. In case of a common race the organiser must ensure a separate classification for each division.

The competitions will be run according the FIA Sporting Code and its Appendices and 2023 SPORTING REGULATIONS OF FIA EUROPEAN RALLYCROSS CHAMPIONSHIP except of Art. 1, 2, 3, 4, 5.3, 6, 8, 9, 10, 11, 13.3-13.5, 14.4 (CLO), 15.2c (first corner), 17.1 (point 23), 17.4, 19, 20, 21.

All Forms of a Briefing has to be in English (or translated to the English).

Additionally:

If a competitor wishes to participate within a Division where he is already classified with a replacement car with a lower engine capacity, he has to respect the weight of the relevant class of this Division.

A Joker Lap and a starting grid situated outside the track are recommended.

There will be 3 or 4 Heats at each competition.

Number of the cars on the grid for less than 11 cars:

| Number of the cars | Q1 | Q2 |
|--------------------|----|----|
| 10 | 5 | 5 |
| 9 | 4 | 5 |
| 8 | 4 | 4 |
| 7 | 3 | 4 |
| 6 | 3 | 3 |

To be classified the driver must finish in minimum 1 Heat, reaching the same number of laps as the winner of this Heat and he must participate in a second Heat.

A maximum of 2 cars can be move up to Semi-/Final if a driver is not able to start.

The driver who causes a false start in a Heat, Semi-/Final must do the Joker Lap for a second time.

If there is no Joker Lap available, the driver who causes a false start in a Semi-final or Final will be fined by 10 seconds resp. for a false start in a heat by 3 seconds.

A judicial camera is obligatory. Throughout the Competition, all Competitors must have installed in their car a judicial camera. It is the responsibility of each Competitor to ensure that the camera is positioned in such a way that the track and the steering wheel are clearly visible, that the camera batteries are sufficiently charged and that the SD recording card is in place and has sufficient capacity to record all of the races. The penalty (up to exclusion from the Competition) for non-compliance will be at the discretion of the stewards. The weight of the camera system is included in the minimum weight of the car. The onus is on the Competitor to ensure the judicial camera is switched on and recording for all practice sessions, races, Semi- Finals and Finals. The camera must work as soon as the car enters the pre-grid area and must not be switched off until it returns to the paddock. Championship officials must be able to access the footage at all times during the Competition following a protest or otherwise. The images must be viewed using the equipment (computer) of the Competitor, who must ensure this equipment is working.

7.5 Classification

The classification will be done according the 2023 SPORTING REGULATIONS OF FIA EUROPEAN RALLYCROSS CHAMPIONSHIP Art. 15.6 to 15.8.

In Division SuperTouringCars class -1600 cc and class -2000 (+1600-2000) cc and class +2000 cc will run separately, each class will get championship points.

The following drivers will be declared winners of the Central European Zone Rallycross Championship at the end of the year:

- The driver having scored the most points in Division SuperCars
- The driver having scored the most points in Division Super1600
- The driver having scored the most points in Division STC-1600
- The driver having scored the most points in Division STC-2000
- The driver having scored the most points in Division STC+2000

CEZ TECHNICAL REGULATIONS FOR RALLYCROSS CARS

Voice radio communication between the driver and his team is allowed in all divisions. The use of a protective polycarbonate windshield film is strongly recommended for all RX divisions.
The use of diesel engines is prohibited.

DIVISION AND CLASSES

1. SuperCars

- cars homologated in group A = 4x4 cars with a max. engine capacity of up to 3500 ccm and cars with one driven axle with an engine capacity exceeding 4000 ccm, corresponding to Appendix J of the ISC FIA (Article 251-255) with a max. range of modifications according to the current Appendix J of the ISC FIA (Article 279). The air restrictor for turbocharged engines shall have an internal diameter of not more than 45 mm (see Figure 254-4).
- cars 4x4 up to 4000 ccm with expired homologation or cars with one driven axle with an engine capacity of more than 4000 ccm, complying with the regulation according to Article 279 of Appendix J of the FIA ISC for Division 1 cars in the year of completion of homologation and exceptions according to the technical regulation of the ASN's. The weight limits are the same as for SuperCars. For cars with a volume of +3500, the minimum weight is **1380 kg**.

2. Super 1600

- cars homologated in group A and corresponding to Appendix J of the ISC FIA (Article 251-255) with a max. extent of modifications according to Appendix J of the ISC FIA (Article 279).

3. SuperTouringCars

- at least 4-seaters (including 2+2), series-produced vehicles (min. 2500 units during 12 consecutive months) with one driven axle and a fixed, non-removable roof, manufactured after 1.1.1984, which comply with the SuperCars regulations referred to in Articles 279.1 to 279.3 of Appendix J of the ISC FIA (except Articles 5.3, 5.4, 5.5)
- only vehicles of manufacturers listed in the FIA homologation list are recognised for this Regulation

A. TECHNICAL REGULATION OF THE DIVISION SUPERTOURINGCARS (STC)

0. Introduction

Unless otherwise specified in this Regulation, Articles 251 (Classification and Definitions), 252 (General Regulation), 253 (Safety Equipment) and 279 of the Appendix J of the ISC FIA shall apply. Variable timing motors are allowed.

01. Definition

STC car:

Minimum 4-seater (including 2+2), touring, mass-produced wagons (min. 2500 units during 12 consecutive months) with a fixed, non-removable roof, with one-axle drive, manufactured after 1.1.1984, which comply with the regulations for STC vehicles (max. capacity 4000 cc, turbocharger with max. diameter 45 mm, catalytic converter any, max. noise limit 100 dB, safety equipment of the vehicle according to the FIA Standards (safety tanks with a maximum capacity of 20 litres with an extended service life of 5 years, safety seats with an extended service life of 5 years) and the Technical Regulation for the STC Division (only vehicles of manufacturers listed on the FIA homologation list are recognized for this regulation).

STC classes:

- STC-1600 ccm - cars with maximum (and recalculated) engine capacity up to 1600 ccm
- STC-2000 ccm - Cars with a maximum (and converted) displacement over 1600 ccm and up to 2000 ccm
- STC+2000 ccm - cars with maximum (and recalculated) displacement over 2000 ccm

Conversion for turbocharging = 1.7 for petrol engines.

02. Supplements

The car does not have to have FIA homologation, the car manufacturer must be on the FIA list of manufacturers (cars properly sold in the dealership are accepted)

1. Generally

1.1 Engine

The engine and its components are free, but the engine block must come from a car model of the same brand as the body.

1.2 Obligations of the competitor

Upon request, the competitor is obliged to prove to the technical and sports commissioners that the vehicle entered by him complies with the regulations for the entire duration of the event.

1.3 Telemetry / voice communication / cameras

Any form of telemetry, GPS systems is prohibited.

Recording cameras, which scan the area in front of the car and operate throughout the journey, are mandatory.

2. Dimensions and weights

2.1 Minimal weights:

For STC cars applies:

Min. weight of the vehicle with the rider in the car, including its complete safety equipment and including liquids remaining in the vehicle at the moment of weighing, must be according to the converted engine capacity according to the table below:

| Engine capacity | Min. weight |
|-----------------------|-------------|
| to 1000 ccm | 780 kg |
| to 1000 over 1400 ccm | 870 kg |
| to 1400 over 1600 ccm | 970 kg |
| to 1600 over 2000 ccm | 1070 kg |
| to 2000 over 2500 ccm | 1100 kg |
| to 2500 over 3000 ccm | 1180 kg |
| to 3000 over 3500 ccm | 1270 kg |
| to 3500 over 4000 ccm | 1350 kg |

2.2 Dimensions

The wheelbase must remain original, as must the wheelbase of the skeleton model with a tolerance of +/- 1%.

The body width (track) can be increased by 70 mm on each side compared to the original model. The width of the bodywork shall be measured above the axle of the wheels.

3. Engine

3.1 Basic data

Type: The engine is arbitrary, but the engine block must come from a car model of the same original brand as the original body. There may be only one direct mechanical connection between the accelerator pedal and the engine load monitoring device. For turbocharged engines is allowed el. Throttle control (according to Art. 279 para. 5.4.2.2. h, J FIA).

Engine location: original space of the brand's model

Engine position: the transverse (or longitudinal) axis of the engine may extend more than 50% beyond the axis of the front wheels towards the rear.

3.2 Airbox, turbocharging

Airbox: free (naturally aspirated engine or turbo engine)
variable suction forbidden

Restrictor:

Turbocharged engines must be equipped with a restrictor with a maximum internal diameter of 45 mm at the turbocharger inlet — see fig. 1 if the diameter of the turbo compressor chamber inlet is greater than 45 mm. The installation of the restrictor on a turbocharger must be carried out in such a way that two screws need to be completely removed from the compressor body or restrictor in order to separate the restrictor from the compressor. The screws must be drilled for sealing. The restrictor is not mandatory if the diameter of the compressor inlet is less than 45 mm (this inlet shall not be a removable part of the compressor housing).

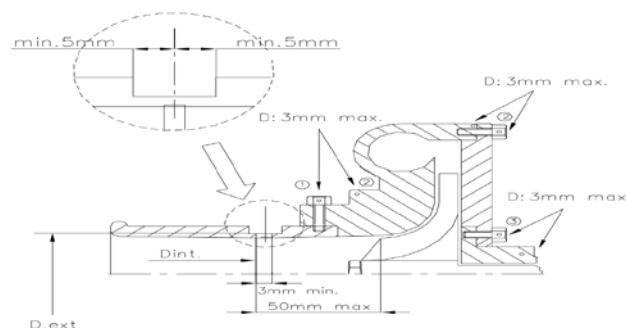

Drawing 1

The outlet of the waste-gate exhaust gas bypass shall be made to the exhaust system and shall not be recycled in any way. In addition, there must be no connection between the intake and exhaust systems. Water injection is prohibited, even if it was originally homologated. Spraying of the charge air intercooler is prohibited. Vehicles with turbocharged engines shall not be fitted with any device enabling the rider to control the boost pressure or with an electronic control system controlling the boost pressure (other than the accelerator pedal) while driving. Ceramics elements, variable diameter inlets and internal blades are prohibited on turbocharges.

Air filter including airbox and location: free
Filling the engine with fuel: carburettor or arbitrary injection
Distribution: variable distribution allowed
Mechanical parts of engine: free (piston, connecting rod, flywheel, cam, oil hosp...)

3.3 Exhaust

Implementation: any under the condition of maintaining the max. noise level
Noise: **max. 100 dB (A) in 4500 rpm.**
Outcome: behind half of the wheelbase, not downwards, inside the bodyshell
Catalyst: none mandatory

3.4 Engine cooling

Type: any cooler including fan
Location: any, must not directly interfere with the rider's compartment (separation from the rider's compartment)

Air intakes: can pass through the rider's compartment, the area of air inlet and outlet to and from the body can be max. the same as the radiator area

4. Fuel system

4.1 Fuel tank

Types:

Serial or made of Al alloy sheet metal (min. thickness 2 mm + foamless filling – see conditions below) or FIA safety (FT3 standard) with a service life extended by 5 years (5+5)

Conditions for the tank made of sheet metal of Al alloy: It must be made of aluminium sheet with a minimum thickness of 2 mm and the material must comply with EU standard No. EN-AW1052A-H24. Maximum volume 20 litres.

- a) Tank welding shall be carried out by a licensed non-ferrous metal welding officer.
- b) The inside of the tank must be filled with safety foam (material) according to US standard no. MIL-B-83054.
- c) The safety foam can be replaced by using a "D-STOP" anti-explosive foil on the outside of the tank.
- d) No anchorages shall be welded to the tank and the tank shall be fixed to the rigid structure of the wagon only by means of strips of metallic material.
- e) The inlet and outlet pipes from the tank shall be of a flexible type to prevent rupture of the tank or the pipes due to deformation.
- f) The tank shall be separated from the crew compartment and at least 300 mm from the extreme outer edge of the vehicle when viewed from above. Partitions shall be provided in accordance with Article 279A 3.12.1.
- g) Tank venting shall not be led out into the crew compartment or engine compartment. It shall be equipped at least with a gravity ventilation valve located on the tank.
- h) The conditions of points (a) to (d) shall be documented when testing the vehicle.

Location: min. 300 mm from the skeleton (except serial), impermeably separated from the space for driver. If a series fuel tank is used (always in the original position only), the condition of a distance of 300 mm from the contour of the vehicle when viewed from above need not be complied with.

Filling: Safe, multifunctional valve (function: overpressure, gravity, ventilation) Overflow protection

Fuel collection valve: none mandatory

4.2 Fuel pumps, circuit – type of connections, fuel collection valve

Pumps: type any, separate from the rider's compartment, operating only in conjunction with the engine running except for starting.

Fuel line, type of connections:

Fuel lines shall be damage-resistant, fireproof, bolted, in a crew compartment without joints, separate from the rider's compartment.

4.3 Fuel

Acc. to FIA (BA, NM).

5. Electrical equipment

5.1 Battery, wiring

Battery:

Type: free

Location: any with limited placement in the rider's compartment, where it must always be behind the level of the backrest

Fixation: always laid on metal. bed, attached by 2 screw callipers min. M8 wet in the D area completely covered by a non-conductive ventilated cover, dry in the D area with the + pole covered. Batteries located outside the J area must always have a covered + pole

Wiring: Securely made and covered connections, non-conductively insulated live conductors

5.2 Generator

Type: any including location. Nominal voltage 12 V.

5.3 Lighting System

Lights

Rear: 2 x red STOP light (60 cm²) + 1 x red fog lamp, located in suitable height in relation to the car behind it, not covered by the wing

Front: the original lights must be removed and the holes covered with plastic. The lights must be lit even when the disconnecter is in the OFF position.

6. Gears

6.1 Clutch

Type: lamellar, hydraulically operated by pedal, other arbitrary

6.2 Gearbox

Type: mechanically (manual) gearbox (sequential, synchronous system Hewland, synchronized), automatic transmissions prohibited

6.3 Gearbox case

Number of gears: free

Sizes of gear ratios: free

Final drive: free

6.4 Shafts

Design: any design of half-axles and ev. and longitudinal shafts

6.5 Differential

Type: mechanical, self-locking. The use of a differential with a viscous clutch is allowed. Differential control el. magnet is prohibited.

7. Suspension

7.1 Reinforcement, replacements

Reinforcement of suspension elements and their attachment points is permitted if the reinforcement material copies the original shape and touches it (applies to suspension elements and suspension attachment points). The suspension reinforcement shall not form hollow bodies or allow two different parts to be joined together. Silent blocks and slide guides can be replaced by the "Uniball" system.

Changing the settings of springs and dampers from the crew compartment is prohibited.

Demountable steel sub-frames for fixing the axles (suspension) are permitted (however, the frame for the front axle must not be connected to the frame for the rear axle). Changes to the skeleton, necessary for the location of suspension elements, drive shafts, compl. bikes are allowed. The maximum number of frame attachment points is 6.

Active suspension is prohibited.

7.2 Front axle, suspension points

Design: acc. to App. 279 - 8.2 App. J ISC FIA

Front shock mount: to store the shock absorber, it is possible to use an atypical hat of the upper bearing including the upper mounting plate.

7.3 Rear axle, suspension points

Design: acc. to App. 279 - 8.3 App. J ISC FIA

Rear shock mount: to accommodate the shock absorber, it is possible to use an atypical hat of the upper bearing including the upper mounting plate within the dimensions according to drawing 279-1.

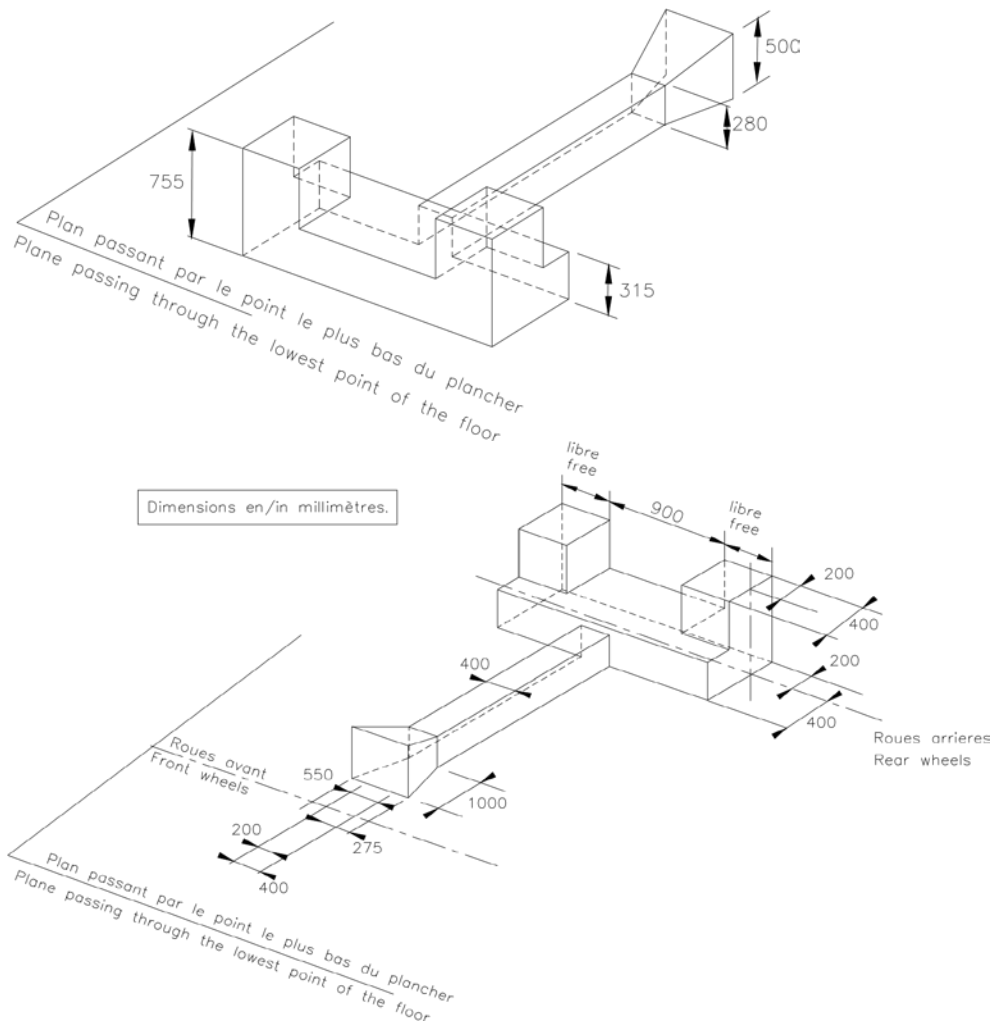

Drawing 279 - 1

7.4 Springs

the length is arbitrary, as well as the number of coils, wire diameter, outer diameter, spring type (progressive) and spring seat shape. The number of springs and seats is arbitrary, provided that the springs are mounted in series.

7.5 Stabilizer

The stabilizer can be disconnected or removed.

7.6 Shocks

Number on wheel: one on wheel

Type, function: free

Mark: free

Shock travel: free

7.7 Reinforcing struts

Reinforcing struts can be attached to mounting points on the body. The condition is that the struts are removable and are attached by a weld or bolts or pins.

The distance between the suspension attachment point and the strut attachment point shall not exceed 100 mm

8. Chassis

8.1 Wheels

Dimensions: max. disc diameter 18", complete wheel (tyred) with width must fit in U 250 mm

8.2 Tyres

Tyre tread pattern is free

8.3 Brakes

Brake system: dual-circuit hydraulic system, controlled by one pedal, others arbitrary

System ABS: must be removed – decommissioned

Mud scraping equipment from discs and/or wheels may be added.

A device can be fitted to protect the brake discs from flying stones.

8.4 Parking brake

Design: a working handbrake is mandatory, on which it is allowed

- replace the mechanical handbrake with a hydraulic system
- change the position of the hand-held hydraulic brake lever, provided that it remains on the central tunnel
- Adjust the handbrake lever mechanism for immediate release (fly-off system).

8.5 Safety

The brake (clutch) fluid reservoirs shall be separated from the D compartment.

8.6 Steering, steering wheel, steering column

The steering column need not be fitted with a deformation or retractable element.

Steering rod bearing reinforcements:

It is possible to add stiffeners under the following conditions:

- must be approved prior to installation by the Technical Committee.

Steering wheel: arbitrary, no quick-sensing device required

9. Bodywork

9.1 Interior, safety equipment (safety construction, seats, belts, extinguishing system, fire extinguisher)

Ventilation system:

Additional installation of equipment for ventilation of the crew compartment (roof air flap h x w = 100 x 500 mm or in side windows) is permitted.

Heating:

The original heater may be removed, but the electric demisting system must be retained (applies to the closed car).

AC: can be removed

Panel:

the dashboard is arbitrary, but it must not pose any danger to the rider.

The centre console can be removed.

Floor:

the floor in the D compartment shall be completely enclosed.

Other soundproofing materials and linings:

It is allowed to remove soundproofing material and lining.

Fluid reservoirs, coolers, pressure pipes:

Fluid reservoirs, coolers, pressure piping and hoses shall be consistently separated (by impermeable cover, bulkhead) from the rider. The rider's compartment must not show dangerous structures (sharp edges, projections, etc.)

9.2 Safety equipment

Safety cage:

The minimum configuration of the protection structure must correspond to the requirements for the min. configuration according to Appendix j of the ISC FIA art. 253-8 drawing 253-36B.

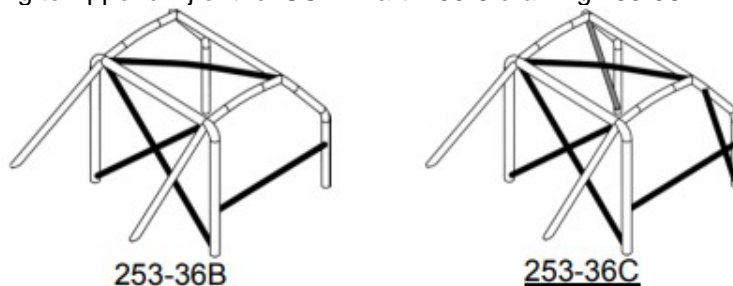

The decisive factor is the date of homologation (start of production of the serial car) and the decision of the Technical Commission when permitting the construction of the car.

For vehicles manufactured before 31.12.2004, the main arch, including any side half-arches, and other elements of the safety structure, may be made of a material with a minimum size of 40 x 2 mm or 38 x 2,5 mm, subject to the conditions laid down in Article 253.8 of Appendix j of the ISC FIA.

The mounting plates of the main cage (stands) of the protective structure do not need to be bolted to the skeleton reinforcement plate (a weld connection is sufficient)
There must be reinforcement of safety cage, if measure A is more than 200 mm

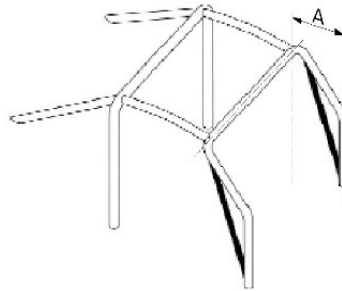

253 - 15

These combinations are minimal, for other options see only App. J FIA Art. 253.8.

Attention: under the anchorage points it is necessary to reinforce the skeleton with sheet metal of thickness 3 mm.

Material and dimensional specifications:

According to App. J

At the point of possible contact of the helmet or body of D with the protective structure, the structure must be lined with a non-combustible material (foam).

Seats, brackets:

It is permitted to move the front seats, but not beyond the vertical plane defined by the front edge of the seat cushion of the original rear seat.

An FIA-approved seat is mandatory (standard 8855/1999 - use limit 5 + 5 years from the date of manufacture or 8862/2009 - use limit 10 + 5 years from the date of manufacture, see Art. 253.16 App. J FIA)

Brackets:

According to Art. 253.16 app. J (crossbars between sill and tunnel + angle of aluminium alloy of min. thickness 5 mm or steel of min. thickness 3 mm + 4 anchor strength bolt joints min. M8 for seat and for holder)

Safety belts:

5 - 6-point, approved according to FIA standard 8853/98 or 8853-2016 with hologram and valid service life, installation according to Art. 253.6.2 App. FIA.

Fire extinguisher:

Mandatory manual fire extinguisher 2 kg with valid revision (manual HP inspection technician). The HP bottle must be properly attached including axial locking. The HP installation must be within reach of the driver.

Fire system:

Built-in FIA-approved fire extinguishing systems are recommended for cars with windscreens.

Additional bonnet and lid attachments:

At least 2 additional attachments must be installed on the hood and lid.

Towing eyes:

Mandatory towing eye front and rear, marked with an arrow and contrasting colour.

Disconnecter of electric energy:

Mandatory external and internal must disconnect all el. circuits and be designated according to Article 235.13 of Annex J.

9.3 Exterior, reinforcement, windows, chassis protection, side protection

Bodywork

The body can only be modified beyond the vertical plane touching the rear wheels and in accordance with fig. 279-1.

The rear longitudinal beams can be adjusted from the axis of the rear wheels.

It is also possible to reinforce the body with stiffeners that do not copy the original shape (they create a profile).

When all these modifications are applied, the supporting function of the basic skeleton must be maintained.

Central (transmission) tunnel

The dimensions must be equivalent to or less than those shown in Figure 279-1, the location may have tolerances of **+/- 100 mm** in the Y-direction, modification according to fig. 279-2 is permitted for the installation of a catalytic converter or silencer

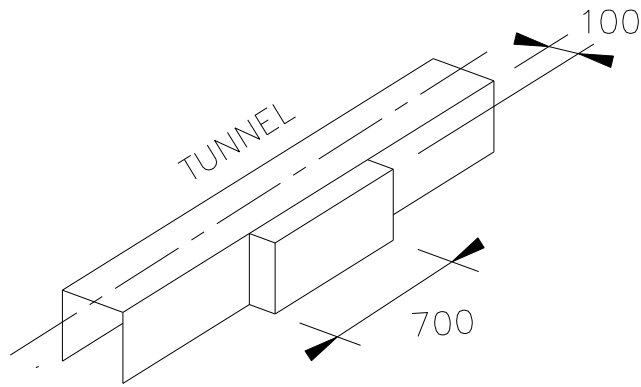
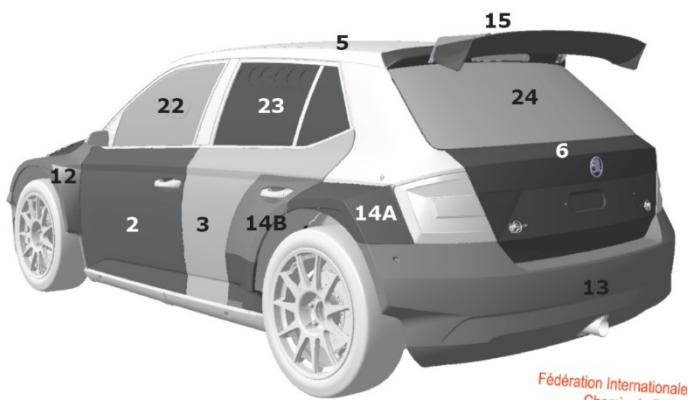
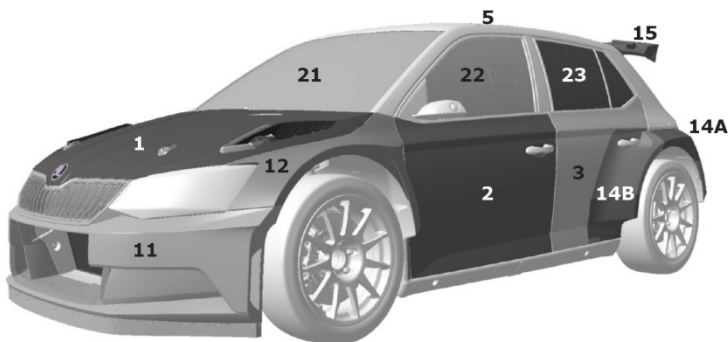

Fig. 279-2

Material specification of the skeleton and surface parts

| | | |
|-----------------------------|---------------------|-------|
| Skeleton | - steel | |
| Floor | - steel | 5 |
| Front, rear fender | - free | 12,14 |
| Front bumper + spoiler | - laminate, plastic | 11 |
| Rear bumper | - laminate, plastic | 13 |
| Rear wing | - laminate, plastic | 15 |
| Holder of rear wing | - Al alloy | |
| 5. door | - free | 6 |
| Bonnet | - free | 1 |
| Floor protection (optional) | - plastic | |
| Drivers' door | - original | 2 |
| Others doors | - free | 3 |



Fédération Internationale

Sound insulation materials can be removed from the inside of the wheel arches, the engine compartment and the luggage compartment. These materials can be replaced by panels (covers) made of sheet metal of aluminium alloy or plastic.

It is allowed to remove exterior decorative mouldings.

Windows:

Front window (pos. 21): original or polycarbonate (Makrolon, Lexan) th. 5 mm

Side window on drivers' side (pos. 22): original or polycarbonate (Makrolon, Lexan) min. th. 4 -0,2 mm

Side and rear windows (pos. 23, 24): original or polycarbonate (Makrolon, Lexan) min. th. 3 -0,2 mm

If windows are replaced by metal mesh, they shall have meshed of a minimum size of 10 × 10 mm and a maximum of 25 × 25 mm, using wire with a minimum diameter of 1 mm.

If a wire with a minimum diameter of 2 mm is used at the driver's door, a protective net need not be installed.

The wagon shall be equipped with working windscreen wiper(s) and working washer (for a closed car)

It is allowed to remove the lower cladding of the windshield (window).

A windscreen lower trim may be modified according Art. 279-10.2.4 of App. J ISC FIA.

Doors, side protection:

It is allowed to remove the upholstery and soundproofing material of the door and ev. from the space under the rear side window (2 door car) and replace it with a panel of sheet metal of aluminium alloy with a thickness of at least 0.7 mm or a panel of non-combustible material of thickness. min. 2 mm. The rider's door must be original, including material. The door reinforcement can only be removed under the condition that it will be replaced without security. foam with a volume of min. 60 l.

Bonnet

The shape of the bonnet shall be based on the shape of the original bonnet. The bonnet does not need to be replaceable by a standard bonnet. The maximum deviation from the original shape of the bonnet may be 100 mm (measured vertically).

The bonnet can only be modified (adding openings and inflators) to improve the air intake and heat dissipation to and from the engine compartment. The modification must not imply an improvement in the aerodynamic properties of the car. The holes in the hood must be covered with a grid, the attachment must be made through 4 points (pins), the original locks must be removed (pos. 1 and 6).

Bumpers:

For fixing the bumpers, it is allowed to add additional fastenings (in addition to the original fastenings, which must be preserved), however, the formation of so-called "rams" is prohibited.

Fenders:

Due to the possible extension by the permitted 2 x 70 mm, it is possible to attach a rim made of min. thickness material to the mudguards. 2 mm. The collar (mudguard) must cover the wheel in such a way that it cannot be seen above the wheel axis when viewed from above.

Aerodynamic elements

Front aerodynamic element:

Material and shape of the concept arbitrary, limited:

- a vertical plane passing through the axis of the front wheels and a horizontal plane passing through the highest point of the rim (fig. I - 1),

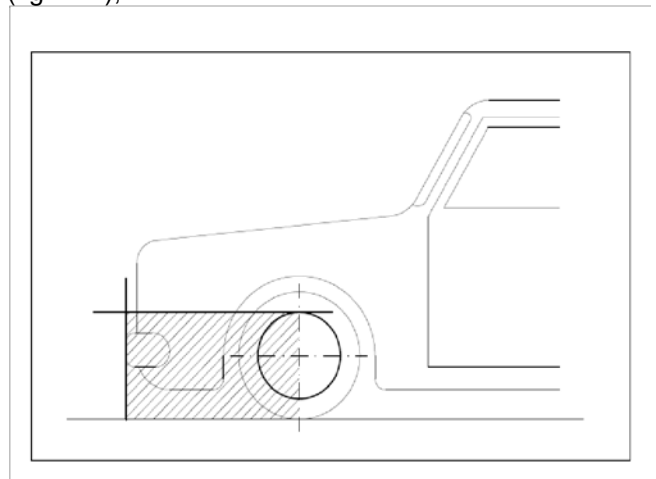

- 1

- the total length of the production car
 - towards the front by the vertical projection of the bumper of the original car
- A hole or holes can be made in the bumper, the total area of which must not exceed 2500 cm². These openings shall not impair the structural integrity of the bumper.

The material thickness of the aero element must be a minimum of 2 mm and a maximum of 5 mm.

Front brace:

it must remain original, without modification and/or may be replaced by a steel pipe according to Annex J, Art. 279, Cap. 10.2.14.

Rear aerodynamical device:

Rear wing – max. dimension: width 1360 mm, the wing side plan must fit into the rectangle $h = 290$ mm, $w = 450$ mm

Rear wing - position: the wing must not extend beyond the plan contour of the car

If the vehicle has a homologated original aerodynamic device larger than permitted by the above wording of the regulation (App. J FIA), it may be retained in its original form.

Lower protection:

The lower protection (skid) must not extend beyond the bumper crossbar. Min. th. 4 mm for Al alloy and 2 mm for steel.

10. Driver´s Safety Equipment

1. Helmet (acc. TL n. 33, 49)

Mandatory according to standards FIA: 8860-2004, 8860-2010, 8858-2015 and SNELL: SA2010, SAH2010, SA2015.

2. Drivers' equipment (acc. TL n. 27 overall, underwear, balaclava, gloves, shoes)

Mandatory according to standards FIA: 8856-2000 with FIA Hologram label or 8856-2018.

3. FHR (acc. TL n. 36 HANS system, Hybrid system, Hybrid Pro system, HANS Adjustable system) Optional, if used, must be according to standards FIA 8858-2002 or 8858-2010 and in combination with compatible helmet (according to SNELL: SA2010, SAH2010 resp. FIA: 8858-2002, 8858-2010) z TL n. 41